

H10Z0812MP

10X 8~80 mm F1.2

for 1/2" format cameras

C-Mount

with Preset

Model No.	H10Z0812MP		Effective	Front	φ 54.0 mm
Focal Length	8~80 mm		Lens Aperture	Rear	φ 14.0 mm
Max. Aperture Ratio	1:1.2		Back Focal Length	15.3 mm	
Max. Image Format	6.4×4.8 mm (φ 8 mm)		Flange Back Length	17.526 mm	
Operation	Iris	Motorized, F1.2~22C	Mount	C-Mount	
	Focus	Motorized, Preset, 1.5m~Inf.	Filter Size	M62×0.75 mm	
	Zoom	Motorized, Preset, 8~80 mm	Tripod Screw	1/4"-20UNC	
Object Dimension at M.O.D.	8 mm	124.8×92.5 cm	Dimensions	W70×H79.5×D123.5mm	
	80mm	17.6×14.4 cm	Weight	670 g	
Angle of View	D	54.3° ~5.8°			
	H	44.0° ~4.7°			
	V	33.3° ~3.5°			
Control	Iris		Focus		Zoom
	Supply Voltage	DC 8 V	DC 8 V	DC 8 V	DC 8 V
	Current	20 mA or less	50 mA or less	45 mA or less	45 mA or less
	Transit Time	Approx. 4 sec.	Approx. 4 sec.	Approx. 4 sec.	Approx. 4 sec.
Preset Potentiometer	-		5KVR	5KVR	
Operating Temperature	-10° C ~ +50° C				

M.O.D. : Minimum Object Distance

Dimensions

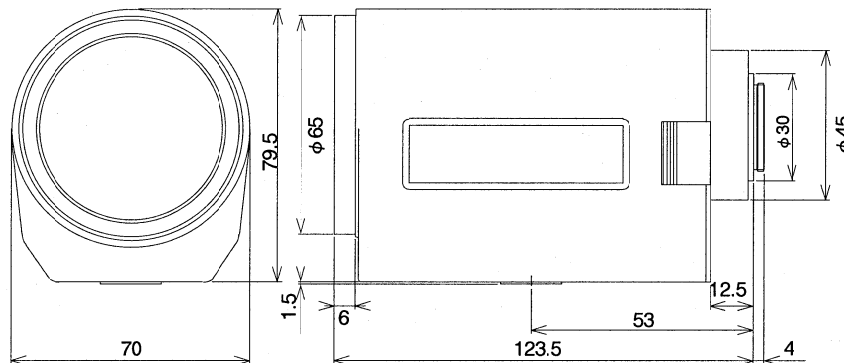

Wiring Diagram

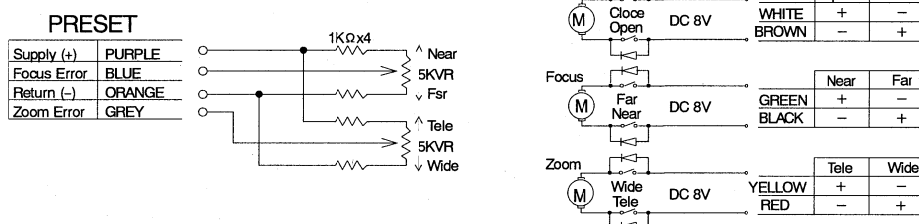

Remarks: Connect together with Brown (Iris), Black (Focus) and Red (Zoom) for common system when necessary.