

T10Z5712MS-CS
10X 5.7~57mm F1.2
for 1/3" format cameras
CS-Mount

Model No.	T10Z5712MS-CS		Effective	Front	φ45.0 mm
Focal Length	5.7~57mm		Lens Aperture	Rear	φ8.6mm
Max. Aperture Ratio	1 : 1.2		Back Focal Length	8.5 mm	
Max. Image Format	4.8 x 3.6mm (φ6mm)		Flange Back Length	12.5 mm	
Operation Range	Iris	F1.2 ~ 560C	Mount	CS-Mount	
	Focus	1.8m ~ Inf.	Filter Size	M49 P=0.75 mm	
	Zoom	5.7~57mm	Tripod Screw	1/4"-20UNC	
Control	Iris	Motorized	Dimensions	W68.5 x H76.3 x D88mm	
	Focus	Motorized	Weight	450g	
	Zoom	Motorized			
Object Dimension at M.O.D.	5.7mm	37.1 x 27.9cm			
	57mm	3.8 x 2.9cm			
Angle of View	D	1/3"	54.2~5.9°		
	H		44.6~4.8°		
	V		34.2~3.7°		
Control	Iris	Focus	Zoom		
Supply Voltage	DC8V		DC8V	DC8V	
Current	25mA or less		20mA or less	20mA or less	
Response Time	Approx. 2 sec.		Approx. 3 sec.	Approx. 3.5 sec.	
Preset Potentiometer	□		□	□	
Operating Temperature	-10°C ~ +50°C				

1/3

CS

M.O.D. : Minimum Object Distance

Dimensions

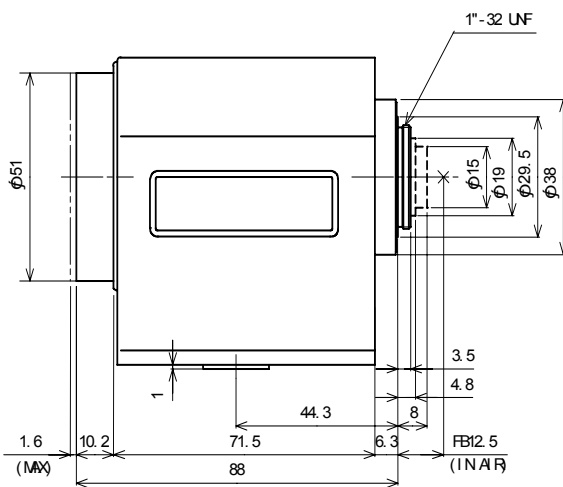
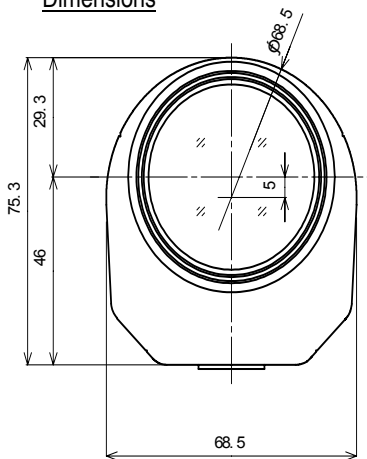

(B&W)

(B&W)
 Using with a B/W camera, Please use the attached "B/W aberration compensation Filter" and "FB compensation Spacer". the filter (M20 P=0.5mm) should be screwed onto the lens from rear side and the spacer should be placed between lens and camera.

ZM

T10Z5712MS-CS
10X 5.7~57mm F1.2
for 1/3" format cameras
CS-Mount

Wiring Diagram

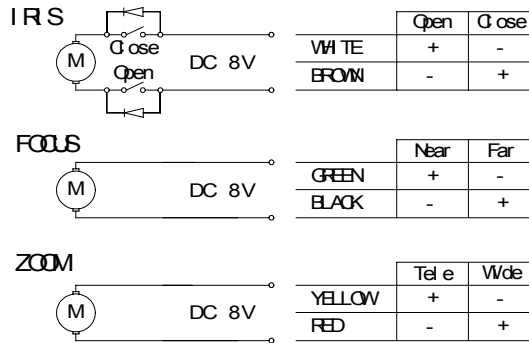

Remarks: Connect together with Brown(Iris), Black(Focus)and Red(Zoom) for common system when necessary.